

CHANDLER

LITTER TREATMENT SPREADER



- 12" 304 Stainless Steel Auger with ¼" Flighting
- Inverted "V"
- Stainless Steel Grate on top of hopper
- 30" – 304 Stainless Steel Spinners
- Spinner Assembly made in 316 Stainless Steel
- Agri-Cover SRT Tarp Assembly

- Available in 11', 12', 13' and 14' (depending on chassis type)
- Hydraulic Drive
- In-Cab Controls
- Scale System
- 304 Stainless Steel Hydraulic Oil Tank
- Rear Mounted Camera
- LED Work Lights
- Stainless Steel Bearings



The Chandler Litter Treatment Spreader is designed for maximum performance when applying materials such as PLT. The hopper is manufactured from 304 grade stainless and the spinner guard and shields are manufactured from 316 grade stainless to handle these corrosive materials. Utilizing a 12" stainless steel auger instead of a conventional chain helps extend chassis life.

Chandler Equipment Co.

Gainesville, Georgia 30503 – 770-536-8891
Toll Free 1-800-243-3319, 770-535-1265 Fax

www.chandlerequipment.net

Chandler Litter Treatment Hopper

“Specifications”

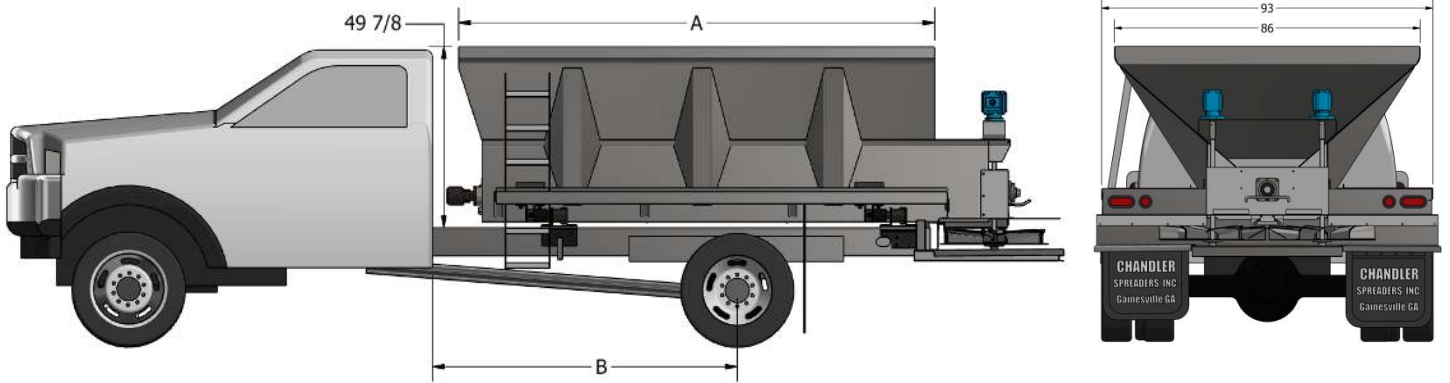

	<u>11' Unit</u>	<u>12' Unit</u>	<u>13' Unit</u>	<u>14' Unit</u>		
A- Hopper	132"	144"	156"	168"	Hopper Width	86"
B - Cab to Axle	84"	96"	108"	120"	Outside Fenders	93"
Height from Truck Frame	49 7/8" (add 2" for Tarp End Cap)				Outside Spread Shield	96"

All Products and Specifications subject to change without notice.



12" 304 SS Auger



Auger Slide Gate



In-Cab Controls

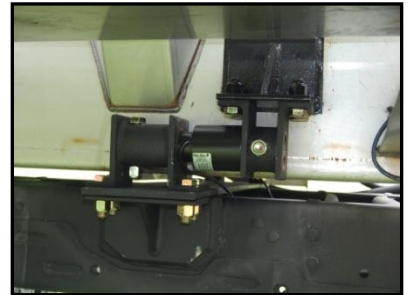

Load Cells



Stainless Steel Grate



Auger Drive



Hydraulic System



Stainless Steel Spinner Assembly

Chandler Equipment Co.

Gainesville, Georgia 30503 – 770-536-8891
Toll Free 1-800-243-3319, 770-535-1265 Fax

www.chandlerequipment.net