

# Chandler SDT – MH 24

## Side Discharge Semi-Trailer Tender



### Trailer: B & B (DOT Trailer)

- 40' – Heavy Duty I-Beam Construction
- Hutch Suspension 9700 – 25,000 # (each axle)
- Tires 255/70R 22.5
- Sealed Beam Lights
- ABS Brakes (air)

### Hydraulic System:

- Tandem High Speed Pump – 3500 PSI
- 30 – Gallon Oil Tank
- Dual 10 Micron Filter Assembly
- Hydraulic Raise & Fold on Discharge Auger

### Hopper:

- 24' Hopper - Available in 304 or 409 Stainless Steel
- 775 Cubic Ft. Capacity
- 3 Hopper, 6 Compartment Design

### Engine:

- Duetz Three (4) Cylinder Diesel Oil/Air Cooled
- 62 Horse Power
- Control Panel with Key Switch Start & Tachometer with Locking Throttle Control
- 16 -Gallon Stainless Fuel Tank



- 20' - 10" 304 Stainless Auger Tube
- Auger - 9" – 304 Stainless Steel Flighting & Pipe

- *Higher Capacity Hydraulic System*
- *Heavy Gauge Material in Hopper*
- *Frame Bolted to Trailer*

---

# **C**handler Equipment Co.

Gainesville, Georgia 30503

Toll Free 1-800-243-3319

[www.chandlerequipment.net](http://www.chandlerequipment.net)

# “SDT – MH 24 Specifications”

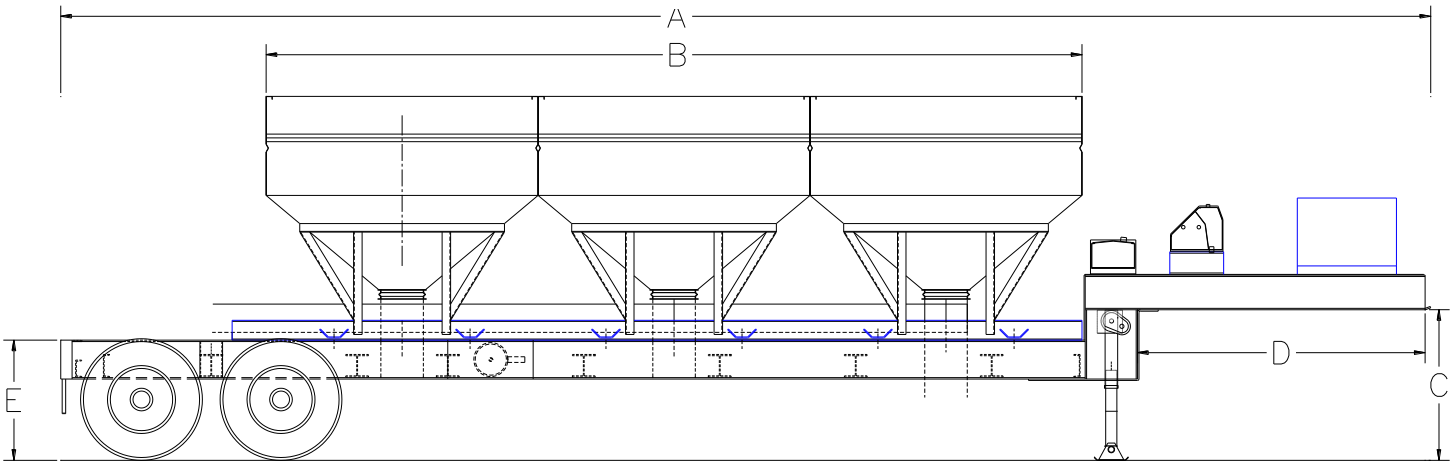

- A – Total Length – 480" (40')
- B – Hopper Length – 288" (24')
- C – Trailer (tongue height) – 53" (4'-5")
- D – Trailer Deck Length – 101" (9'-5")
- E – Trailer Height – 42" (3'-6")
- F – Auger Discharge Height (lowered) – 143" (11'-11")
- G – Auger Discharge Height (raised) - 209" (17'-5")
- H – Discharge distance to Trailer (raised) 83"(6'-11")
- I – Discharge distance to Trailer (lowered) -138" (11'-6")

Empty Weight: 17,960 #

### Optional Equipment:

- Agri-Cover SRT 2 Roll Tarp Assembly
- Electric Motor on Tarp (Remotely Operated)
- 304 Stainless Steel Frame
- Catwalks on Top for Hopper

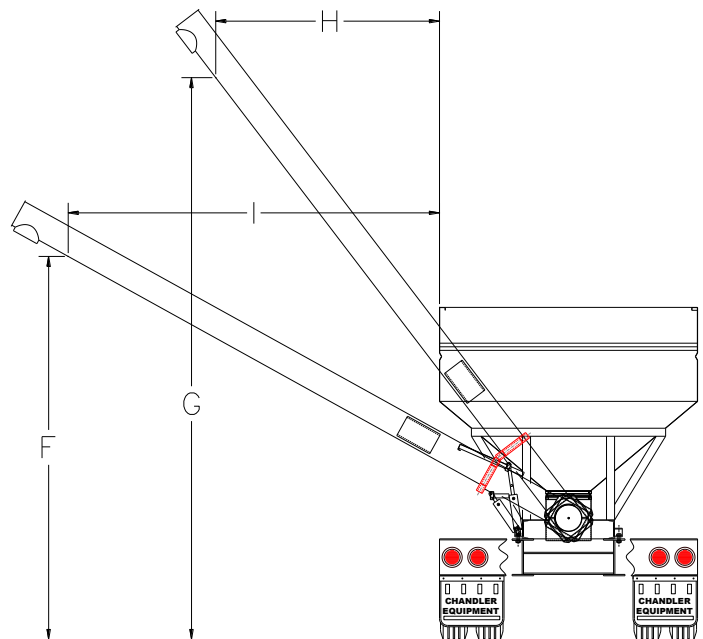

Pit Pump Assembly



Hydraulic Controls



Self Contained Hydraulic System

# Chandler Equipment Co.

Gainesville, Georgia 30503

Toll Free 1-800-243-3319

[www.chandlerequipment.net](http://www.chandlerequipment.net)