

Chandler SDT – MH 18

Side Discharge Truck Mounted Tender



Hopper:

- 18' Hopper - Available in 304 or 409 Stainless Steel
- 575 Cubic Ft. Capacity
- 3 Hopper Design
- Large Hydraulic Gates (standard)
- Auger Clean Door (underneath each hopper)
- Inspection Ladder

Hydraulic System:

- Tandem Pump (3000 PSI)
- 35 – Gallon Oil Tank
- 10 Micron Filter Assembly
- Stainless Hydraulic Tubing
- All JCI & O-Ring Fittings
- Hydraulic Raise & Fold on Discharge Auger



- 20' - 10" 304 Stainless Auger Tube
- Auger - 9" – 304 Stainless Steel Flighting & Pipe
- *High Capacity Hydraulic System*
- *Heavy Gauge Material in Hopper*
- One Point Grease Bank for ALL Bearings

Chandler Equipment Co.

Gainesville, Georgia 30503

Toll Free 1-800-243-3319

www.chandlerequipment.net

“SDT – MH 18 Specifications”

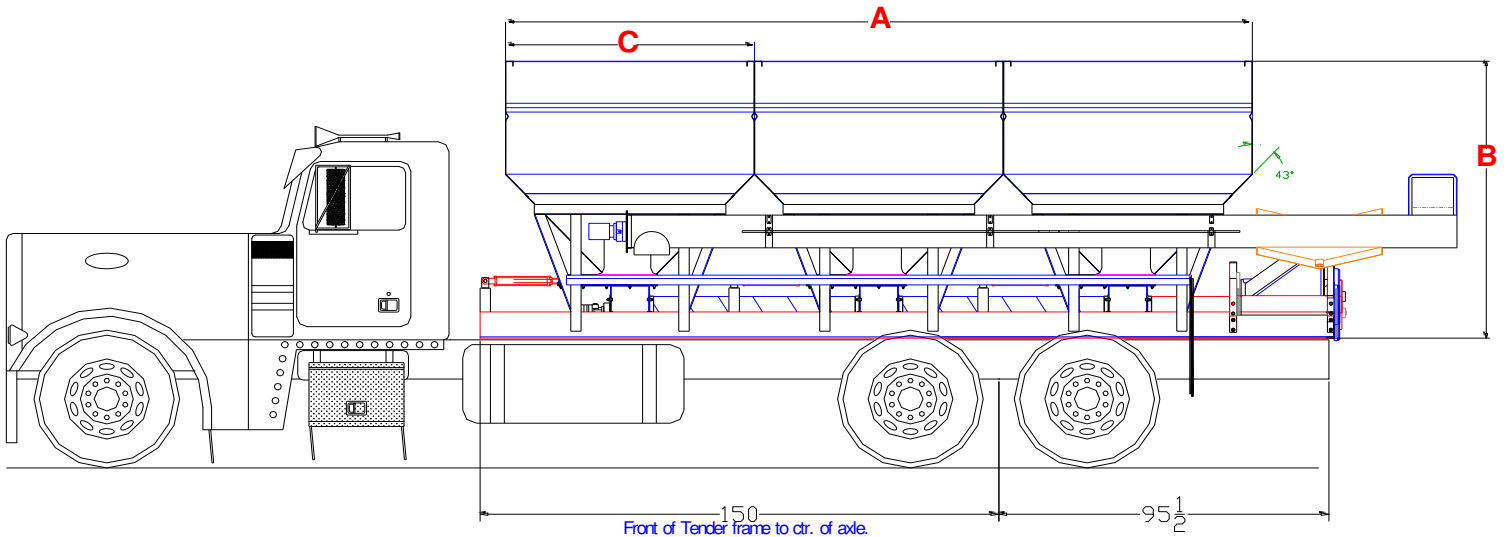

- A – Total Hopper Length – 216" (18')
- B – Hopper Height (from truck frame) – 85" (7'-1")
- C – Hopper Length – 72" (6')
- D – Hopper Width – 96" (8')
- E – Auger Total Height (Lowered) – 157" (13'-1")
- F – Auger Discharge Height (lowered) – 184" (15'-4")
- G – Auger Total Height (raised) - 256" (21'-4")
- H – Auger Discharge Height (raised) 222"(18'-6")

Tender Weight: 6,480#
(with Tarp Assembly & Hydraulic Oil)

Optional Equipment:

- Agri-Cover SRT 2 Roll Tarp Assembly
- Electric Motor on Tarp
- 304 Stainless Steel Frame
- Vibraters (Electric)

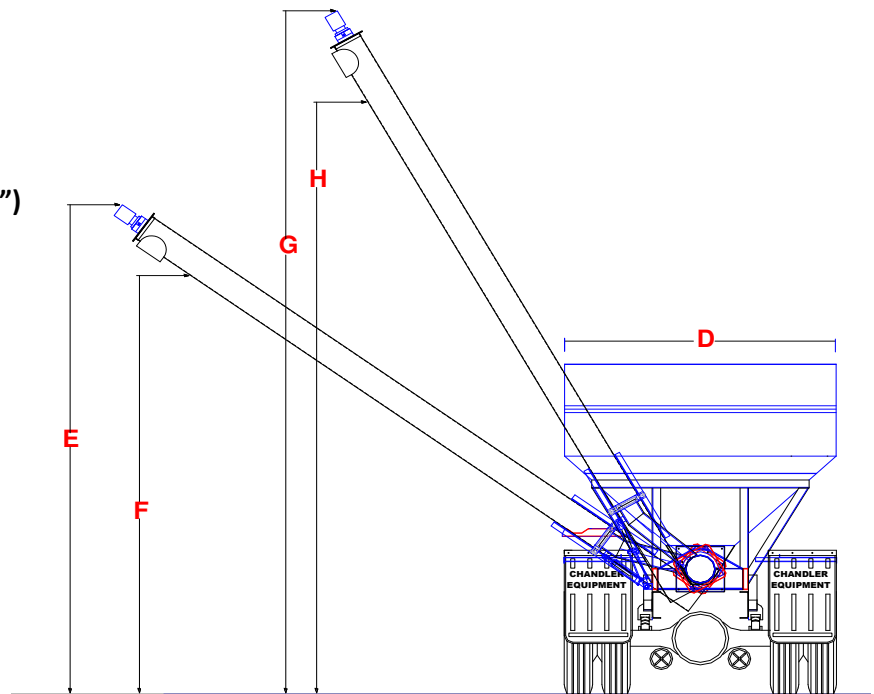

Hydraulic Controls



Pivot Auger Assembly



Hydraulic Gates

Chandler Equipment Co.

Gainesville, Georgia 30503

Toll Free 1-800-243-3319

www.chandlerequipment.net