

# Chandler SDT – MH 16

## Side Discharge Truck Mounted Tender



### Hopper:

- Available in 304 or 409 Stainless Steel
- 500 Cubic Ft. Capacity
- 2 Hopper Design (4-Compartment)
- 304 Stainless Gates (standard)
- Auger Clean Door (underneath each hopper)
- Inspection Ladder

### Hydraulic System:

- Tandem Pump (3000 PSI)
- 35 – Gallon Oil Tank
- 10 Micron Filter Assembly
- Stainless Hydraulic Pipes
- JCI & O-Ring Hose Fittings
- Hydraulic Raise & Fold on Discharge Auger



- 20' - 10" 304 Stainless Auger Tube
- Auger - 9" – 304 Stainless Steel Flighting & Pipe
- *High Capacity Hydraulic System*
- *Heavy Gauge Material in Hopper*
- One Point Grease Bank for ALL Bearings

---

# **C**handler Equipment Co.

Gainesville, Georgia 30503

Toll Free 1-800-243-3319

[www.chandlerequipment.net](http://www.chandlerequipment.net)

# “SDT – MH 16 Specifications”

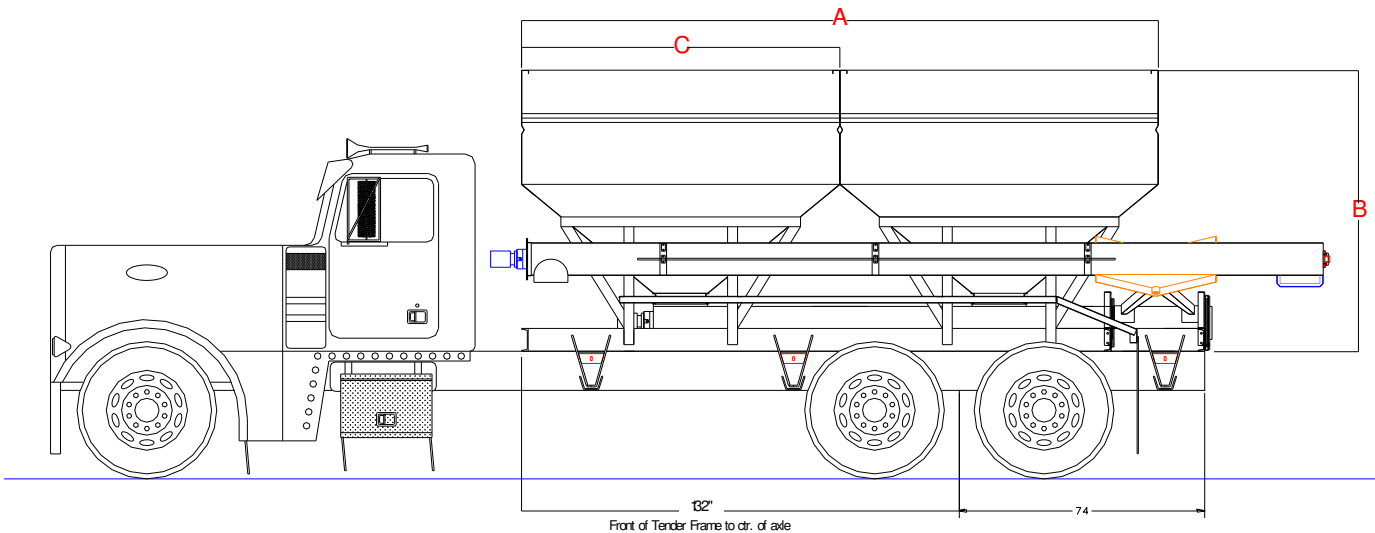

- A – Total Hopper Length – 192" (16')
- B – Hopper Height (from truck frame) – 86" (7'-2")
- C – Hopper Length – 96" (8')
- D – Hopper Width – 96" (8')
- E – Auger Total Height (Lowered) – 162" (13'-6")
- F – Auger Discharge Height (lowered) – 140" (11'-8")
- G – Auger Total Height (raised) - 216" (18')
- H – Auger Discharge Height (raised) 208"(17'-4")

Tender Weight: 5,250#  
(with Tarp Assembly & Hydraulic Oil)

### Optional Equipment:

- Agri-Cover SRT 2 Roll Tarp Assembly
- Electric Motor on Tarp
- 304 Stainless Steel Frame
- Vibraters (Electric)

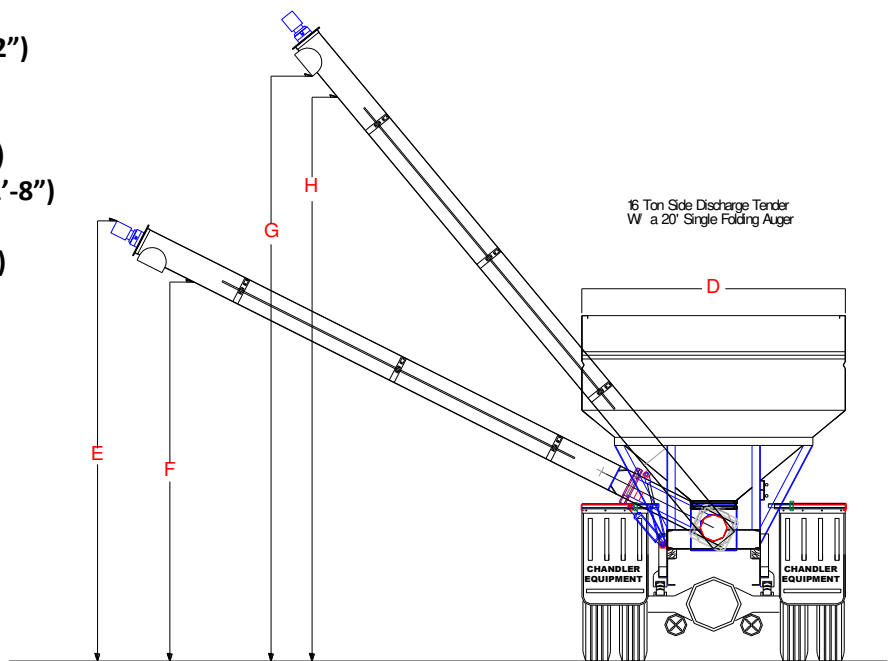

Hydraulic Controls



Pivot Auger Assembly



Stainless Gates

# **C**handler Equipment Co.

Gainesville, Georgia 30503

Toll Free 1-800-243-3319

[www.chandlerequipment.net](http://www.chandlerequipment.net)