

# Chandler RDT

## Rear Discharge Truck Tender



### Hopper:

- 12' or 16' Hopper - Available in Mild Steel w/ 304 Stainless Lower Section, 409 or 304 Stainless Steel (12 Gauge)
- Single Hopper, 2 - Compartment Design
- Mild Steel Channel Frame
- 304 Stainless Steel Gates and Slides (Standard on ALL Models)

### Standard Equipment:

- Ladder – Front and Rear
- 15' - Stainless Auger (RDT-12)
- 18' – Stainless Auger (RDT-16)
- 10" Auger Tube – 304 Stainless Steel Flighting & Pipe

### Hydraulic System:

- Single Pump – 3000 PSI
- 30 – Gallon Oil Tank
- Single 10 Micron Filter Assembly
- Hydraulic Raise & Lower on Discharge Auger



### Optional Equipment:

- 18' -20' - 10" 304 Stainless Auger Tube on RDT-12
- 20' 304 Stainless Steel Auger Tube on RDT-16
- 304 Stainless Steel Frame
- Electric Vibrates
- Agri-Cover SRT 2 Roll Tarp Assembly
- Electric Motor on Tarp

# Chandler Equipment Co.

Gainesville, Georgia 30503

Toll Free 1-800-243-3319

[www.chandlerequipment.net](http://www.chandlerequipment.net)

# “RDT – Specifications”

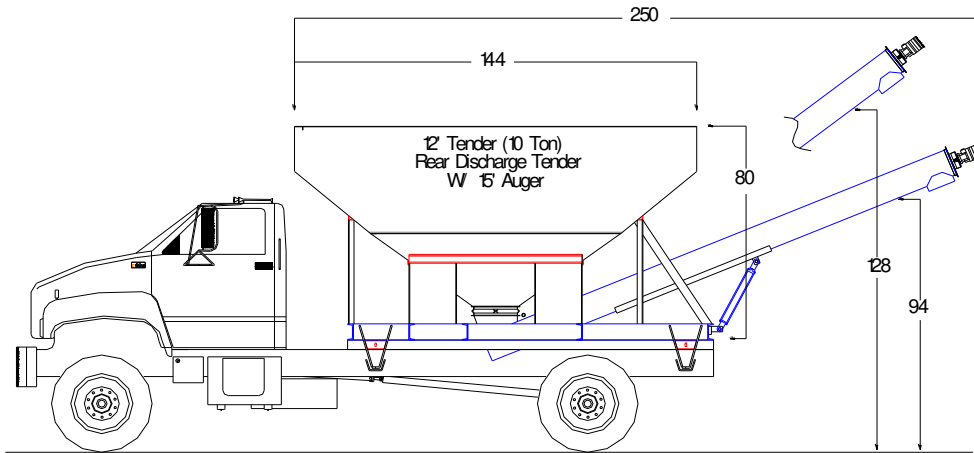

RDT-12 Rear Discharge Tender

## RTD-12

**(310 Cubic Ft. Capacity)**

Tender Weight – 3,200 #

(Recommend CA: 120” – 124”)

- 37 Degree Slope on Sides
- 34 Degree Slope on Ends

## Optional 18' Auger Heights

- Auger Lowered -107”
- Auger Raised -149”

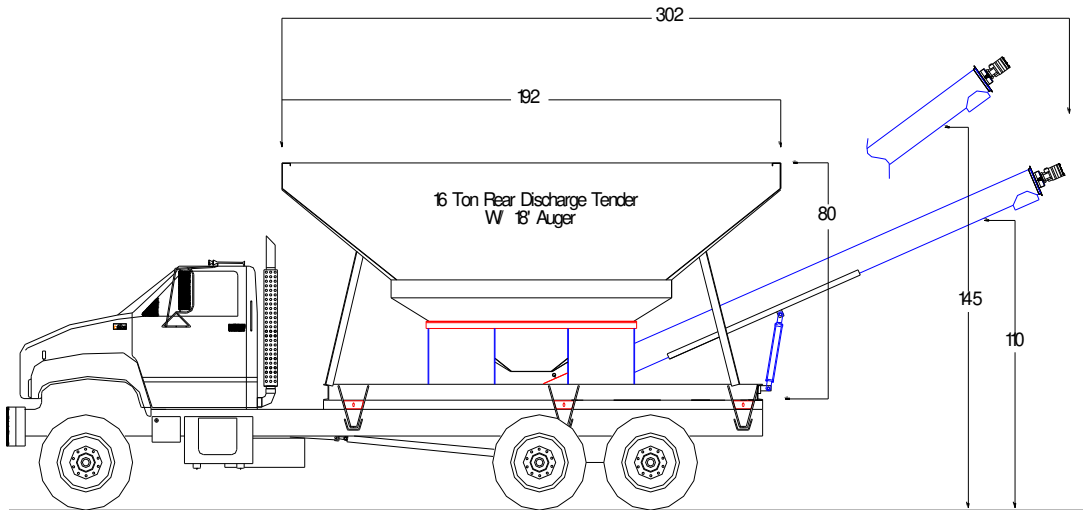

RDT-16 Rear Discharge Tender

## RDT 16

**(495 Cubic Ft. Capacity)**

Tender Weight – 3,990 #

(Recommend CT: 138” – 144”)

- 37 Degree Slope on Sides
- 34 Degree Slope on Ends

## Optional 20' Auger Heights

- Auger Lowered -120”
- Auger Raised -159”



Hydraulic Control Valves



Stainless Steel Gates



Stainless Steel Auger



Hydraulic Cylinder



Vibrators Brackets

**Standard  
Equipment**

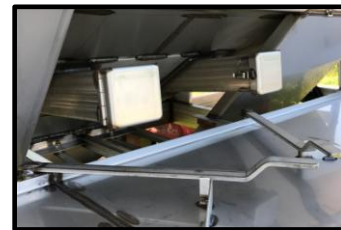

Hopper Clean Out

# Chandler Equipment Co.

Gainesville, Georgia 30503

Toll Free 1-800-243-3319

[www.chandlerequipment.net](http://www.chandlerequipment.net)