

# Chandler Litter Conveyor



**Tongue and hitch easily detaches.**

**Dual 12,000 # Jacks for stability.**

**Heavy Duty Tubing Frame**

**The Chandler Litter Conveyor makes loading spreaders and semi-trailers easy work by loading a 45' trailer in as little time as 15 to 20 minutes (depending on material times may vary) This Conveyor comes standard with a self-contained hydraulic system, powered by a Honda 18 H.P. engine, that allows for easy and trouble free operation. The operator can easily raise and lower the discharge height with our uniquely designed scissor type hoist system that has dual cylinders for smooth operation.**

**Torsion Axle w/ P225R/15 Highway Tires**

**Hopper is designed for easy loading**

**Hopper Width: 98 1/2" front  
Hopper Length: 85 1/2" side**



## Chandler Equipment Co.

Gainesville, Georgia 30503

Toll Free 1-800-243-3319, Fax 770-535-1265

[www.chandlerequipment.net](http://www.chandlerequipment.net)

# Chandler Litter Conveyor

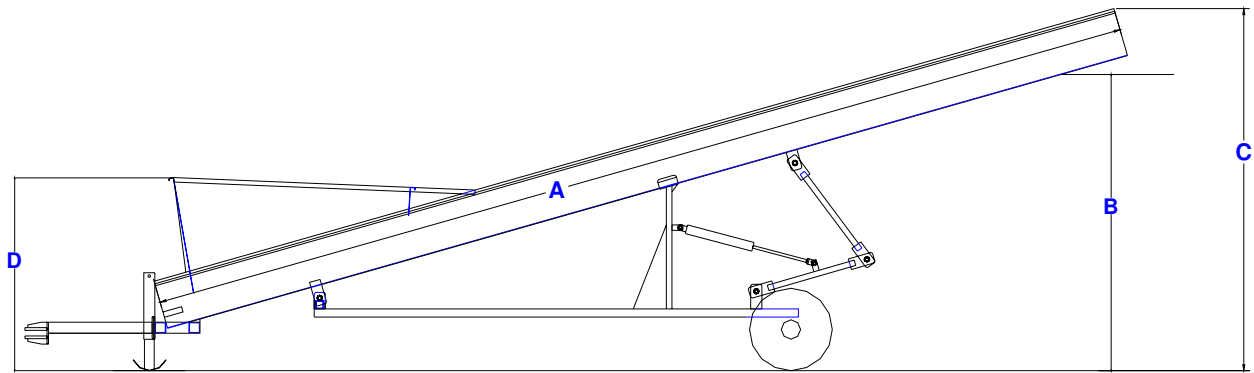

- A) Conveyor Length – 32' (384 inches)
- B) Discharge Height
  - a. Raised – 14'-3" (171 inches)
  - b. Lowered – 10'-1" (121 inches)
- C) Overall Height
  - a. Raised – 16'-6" (198 inches)
  - b. Lowered – 12'-1" (145" inches)
- D) Hopper Loading Height –
  - a. Raised – 5' (60 inches)
  - b. Lowered – 5'-1" (61" inches)



**Self-Contained Hydraulic System**

**Bar Type Chain for High Volume Loading**



**Scissor Type Hoist with Dual Hydraulic Cylinders**



## Chandler Equipment Co.

Gainesville, Georgia 30503

Toll Free 1-800-243-3319, Fax 770-535-1265

[www.chandlerequipment.net](http://www.chandlerequipment.net)