

CHANDLER FTLH - EXW

FERTILIZER AND LIME SPREADER



- Wider Spread Patterns
90' Fertilizer
60' Lime
- Belt-Over Bar Chain or
Mesh Type Chain
- Dished Type Spinners
Designed for Maximum
Coverage on Spread
Pattern
- Designed to Fit Almost
Any Floater Chassis
- Tandem Pump System
with 50-Gallon
Hydraulic Oil Tank

**New Cleaner Design, Wider Spread Patterns
With The Same Dependability**

The new FTLH-EXW has the same dependability, accuracy and reliability that Chandler Spreaders have been known for over the past thirty-eight years with a new cleaner design and wider spread patterns. *Our field proven dished type spinners with a new four-blade system give the Chandler FTHL-EXW an oval pattern that has been the desirable pattern throughout the industry for many years.* All Chandler Spreaders are available with Raven Control systems.

Chandler Equipment Co.

Gainesville, Georgia 30503 – 770-536-8891
Toll Free 1-800-243-3319, 770-535-1265 Fax

www.chandlerequipment.net

Chandler FTLH – EXW Hopper

Specifications

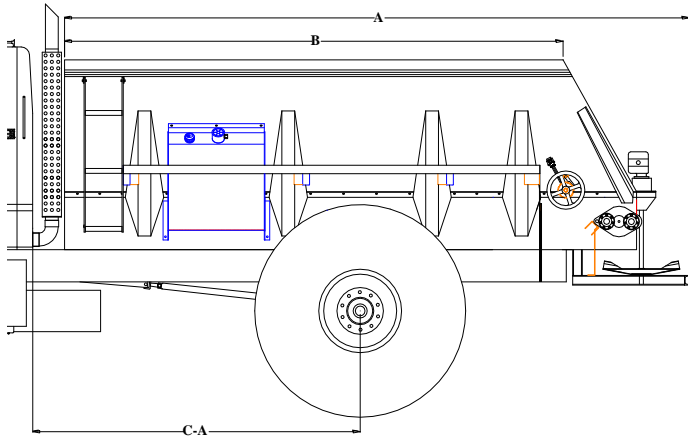

	11' Unit	12' Unit	13' Unit
A – Overall Length	195 ½"	183 ½"	195 ½"
B – Inside Hopper.....	132"	144"	156"
Cab to Center of Axle.....	96"	102"	108"

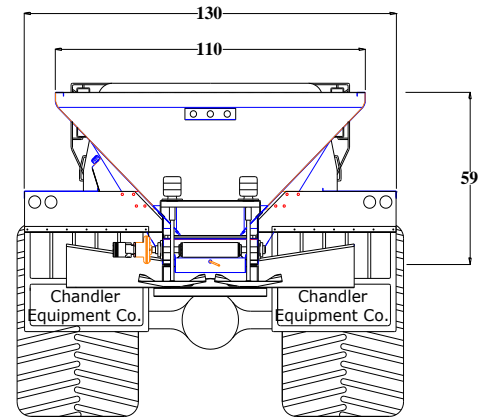

	11' Unit	12' Unit	13' Unit
Hopper Capacity	257 Cu. Ft.	280 Cu. Ft.	303 Cu. Ft.
(Struck Level)			
Payload (struck level).....	16702 Lbs.	18220 Lbs.	19695 Lbs.
(@ 65# Material)			
Hopper Capacity	287 Cu Ft.	310 Cu Ft.	340Cu Ft.
(Heaped & Tarped)			
Payload (Heaped)	18655 Lbs.	20,150 Lbs.	22110 Lbs.
(@ 65# Material)			

Spread Patterns:

Fertilizer up to 90'

Lime up to 60'

All Products and Specifications subject to change without notice. Drawing shown with 45 degree slope sides and 24" Belt Over Bar Chain.

Hopper Construction:

Available in three types of material: Mild Steel, 409 Stainless Steel, 304 Stainless Steel

Conveyor Specs:

Available in three types: 24" - 1" x 1" Mesh Type-304 Stainless Steel, Bar Type Chain and Belt Over – Bar type Chain

Spinner Specifications:

Four blade configuration spinners and a specially designed flow divider for wide swath applications. (60' Lime – 90' Fertilizer)

High Pressure, Double Bearing spinner motors mounted overhead keeps motors out of fertilizer and other contaminants for longer life.



Chandler Equipment Co.

Gainesville, Georgia 30503 – 770-536-8891

Toll Free 1-800-243-3319, 770-535-1265 Fax

www.chandlerequipment.net