

CHANDLER FTL - EXW

FERTILIZER AND LIME SPREADER



- Wider Spread Patterns
70' Fertilizer
50' Lime
- Dished Type Spinners
Designed for Maximum
Coverage on Spread
Pattern

- Belt-Over Bar Chain or Mesh Type Chain
- Designed to Fit Standard and Semi-Float Chassis
- Tandem Pump System with 50-Gallon Hydraulic Oil Tank
- Variable Rate Application Control Systems and Swath Guidance available from Raven Industries



The new FTL-EXW has the same dependability, accuracy and reliability that Chandler Spreaders have been known for over the past Forty years with a new cleaner design and wider spread patterns. *Our field proven dished type spinners with a new four-blade system gives the Chandler FTL-EXW an oval pattern that has been the desirable pattern throughout the industry for many years.* All Chandler Spreaders are available with optional Raven Control systems.

Chandler Equipment Co.

Gainesville, Georgia 30503 – 770-536-8891
Toll Free 1-800-243-3319, 770-535-1265 Fax
www.chandlerequipment.net

Chandler FTL – EXW Hopper

Specifications

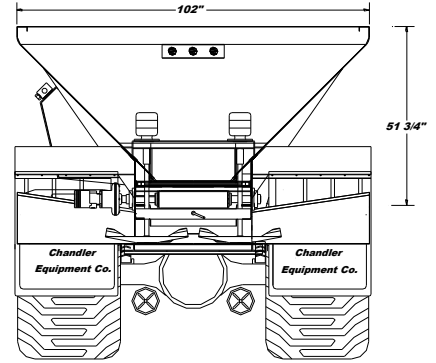
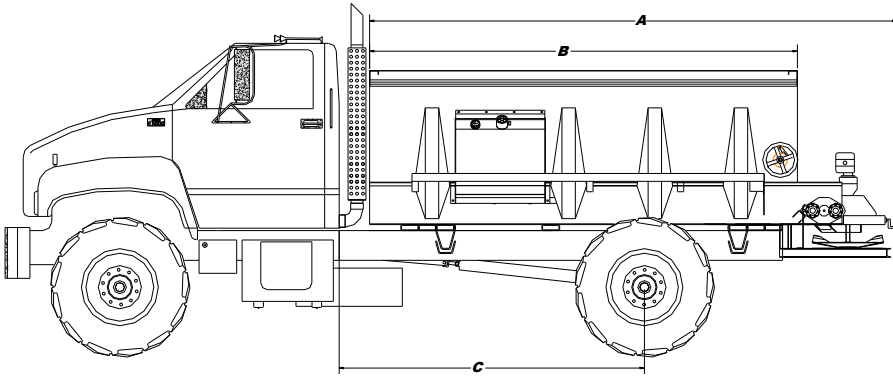

	11' Unit	12' Unit	13' Unit	14' Unit
A – Overall Length	165 ”	177”	189”	201”
B – Inside Hopper.....	132”	144”	156”	168”
Cab to Center of Axle.....	96”	102”	108”	114”

	11' Unit	12' Unit	13' Unit	14' Unit
Hopper Capacity	222 Cu. Ft.	242 Cu. Ft.	262 Cu. Ft.	282 Cu. Ft.
(Struck Level)				
Payload (struck level).....	14,430 Lbs.	15,730 Lbs.	17,030 Lbs.	18,330 Lbs.
(@ 65# Material)				
Hopper Capacity	258 Cu Ft.	290 Cu Ft.	305 Cu Ft.	329 Cu. Ft.
(Heaped & Tarped)				
Payload (Heaped)	16,770 Lbs.	18,850 Lbs.	19,825Lbs.	21,385 Lbs.
(@ 65# Material)				

Spread Patterns:

Fertilizer up to 70'

Lime up to 50'

All Products and Specifications subject to change without notice. Drawing shown with 45 degree slope sides and 24”Belt Over Bar Chain.

Hopper Construction:

Available in three types of material: Mild Steel, 409 Stainless Steel, 304 Stainless Steel

Conveyor Specs:

Available in three types: 24” - 1” x 1” Mesh Type-304 Stainless Steel, Bar Type Chain and Belt Over – Bar Type Chain

Spinner Specifications:

Four blade configuration spinners and a specially designed flow divider for wide swath applications. (50’ Lime – 70’ Fertilizer)

High Pressure, Double Bearing spinner motors mounted overhead keeps motors out of fertilizer and other contaminants for longer life.



Chandler Equipment Co.

Gainesville, Georgia 30503 – 770-536-8891
 Toll Free 1-800-243-3319, 770-535-1265 Fax
www.chandlerequipment.net