

# Model AT – FTLH EXW

## Adjustable Track Row Crop Spreader



### Standard Features:

- True Adjustable Track (Adjustable from 72" -120")
- 380-90R-46 Row Crop Tires
- Heavy 20,000 # Hubs (each)
- Tubing Frame with Bolt-On Hopper
- 24" - 304 Stainless Steel Mesh Type Chain
- Light Kit (Marker, Turn & Flasher)
- Wider Spread Patterns (80' Fertilizer – 50' Lime)

### Optional Equipment:

- Self-Contained Hydraulic System
- CAT-4 Bull Pull Hitch
- Belt-Over Bar Type Chain
- Stainless Steel Spinner Assembly
- Agri-Cover Tarp
- Control Systems from Raven Industries

**RAVEN**



PLATINUM  
PARTNER

- ISO-BUS Ready



“Shown with optional Self-Contained Hydraulic System”

# **C**handler Equipment Co.

Gainesville, Georgia 30503 – 770-536-8891  
Toll Free 1-800-243-3319, 770-535-1265 Fax

[www.chandlerequipment.net](http://www.chandlerequipment.net)

# “Specifications”

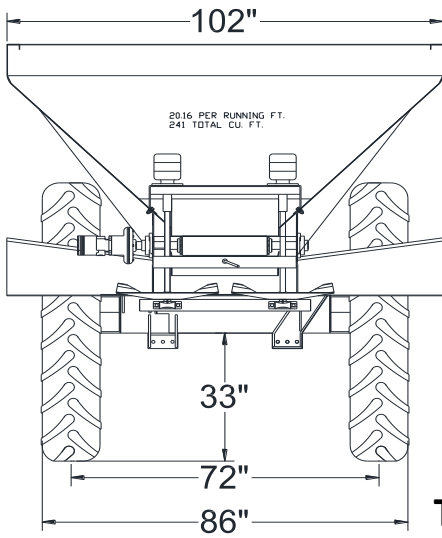
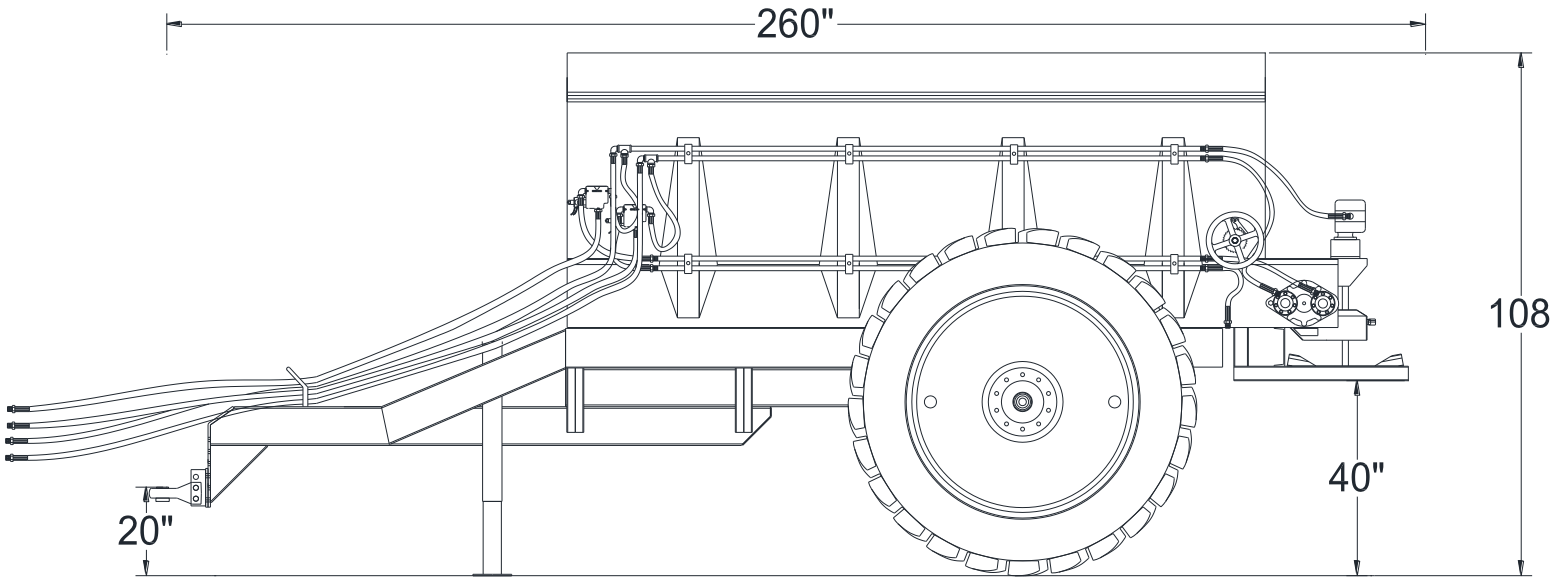

**True Adjustable Track Axle**

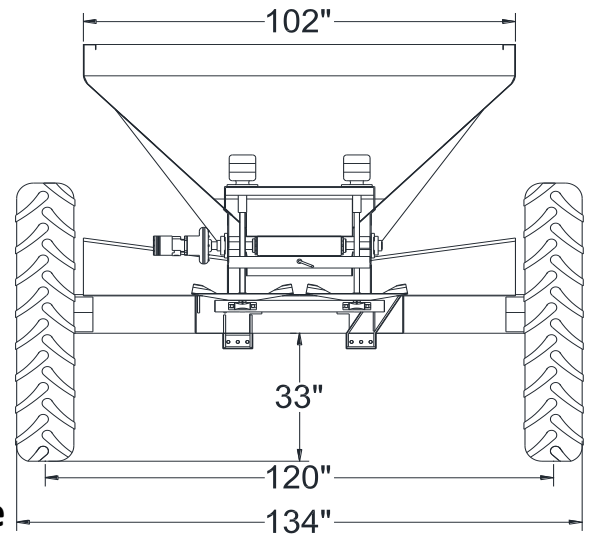

**Hopper Construction:**

Available in three types of material: Mild Steel, 409 Stainless Steel, and 304 Stainless Steel

**Conveyor Specs:**

Available in: Bar Type Chain and Belt Over – Bar type Chain

**Spinner Specifications:**

4- Blade configuration with dished type spinners and a specially designed flow divider for wide swath applications. (50' Lime – 80' Fertilizer)

High Pressure, Double Bearing spinner motors mounted overhead keeps motors out of fertilizer and other contaminants for longer life.



**Warning: Use 120" Track for Fertilizer ONLY!  
Use 90" Track or Less When Spreading Lime**

	<u>Fertilizer @ 65 #</u>	<u>Lime @ 90 #</u>
<b>Hopper Capacity</b> (Struck Level)	<b>280 Cu. Ft.</b>	
<b>Payload (struck level)</b>	<b>18,220Lbs.</b>	<b>24,000 Lbs</b>
	<b><u>Maximum Recommended Capacity</u></b>	

# Chandler Equipment Co.

Gainesville, Georgia 30503 – 770-536-8891  
Toll Free 1-800-243-3319, 770-535-1265 Fax  
[www.chandlerequipment.net](http://www.chandlerequipment.net)