

CHANDLER 45 PTT-FT EXW FERTILIZER AND LIME SPREADER



- Heavy Walking Beam Tandem Axle
- 850/50 – 30.5 Floatation Tires
- Wider Spread Patterns
90' Fertilizer
60' Lime

- Dished Type Spinners Designed for Maximum Coverage on Spread Pattern
- Tandem Pump System with 50-Gallon Hydraulic Oil Tank
- Control Systems available from Raven Industries



The 45 PTT-FT-EXW is the latest in the EXW line. This spreader has the same dependability, accuracy and reliability that Chandler Spreaders have been known for over the past forty years. This spreader is truly in a class by itself with our *NEW Walking Beam Tandem Axle*, floatation tires, and wider spread patterns. Designed for the grower/applicator that is not yet ready to step up to a big self-propelled floatation machine but already has 200-300 HP tractors on their farm and needs something bigger than your average pull type spreader.

This spreader has a capacity of 14-tons fertilizer and 20-tons lime with application rates from 50 # per acre to over 800 # per acre on fertilizer and from 500# to over 4 Tons per acre on lime with ground speeds up to 14 mph.

To learn more about our EXW line of spreaders contact Chandler Equipment or your nearest dealer.

Chandler Equipment Co.

Gainesville, Georgia 30503 – 770-536-8891
Toll Free 1-800-243-3319, 770-535-1265 Fax
www.chandlerequipment.net

Chandler 45 PTT – FT EXW

Specifications

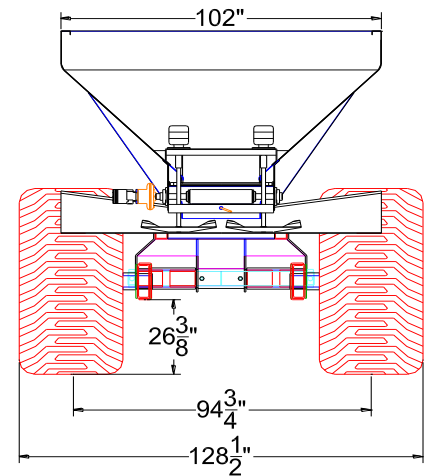
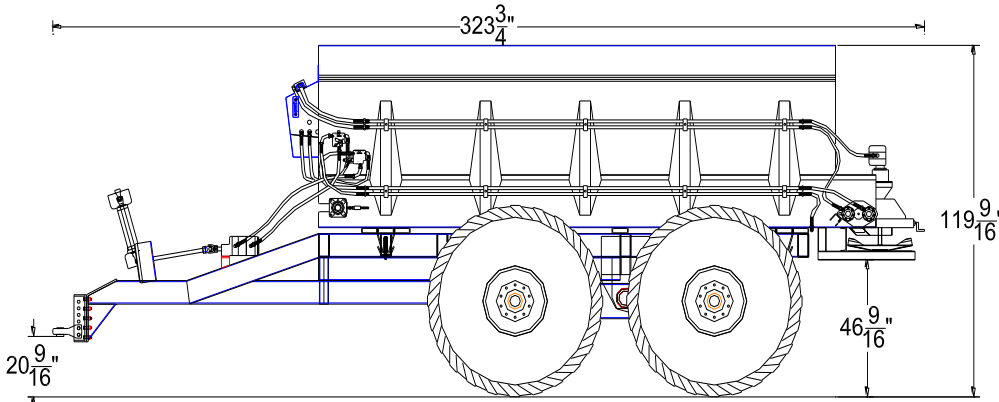

All Products and Specifications are subject to change without notice.

Hopper Construction:

Available in three types of material: Mild Steel, 409 Stainless Steel, and 304 Stainless Steel

Conveyor Specs:

Available in two types: Bar Type Chain and Belt Over – Bar type Chain

Spinner Specifications:

4- Blade configuration with dished type spinners and a specially designed flow divider for wide swath applications.

(60' Lime – 90' Fertilizer)

High Pressure, Double Bearing spinner motors mounted overhead keeps motors out of fertilizer and other contaminants for longer life.

	Fertilizer @ 65 #	Lime @ 90 #
--	-------------------	-------------

Hopper Capacity (Struck Level)	418 Cu. Ft.	
Payload (struck level)	27,170 Lbs.	37,6200 Lbs

Hopper Capacity (Heaped & Tarped)	465 Cu Ft.	
Payload (Heaped)	30,225 Lbs.	40,000 Lbs.

Maximum Recommend Capacity

Spread Patterns:

Fertilizer up to 90' -Lime up to 60'

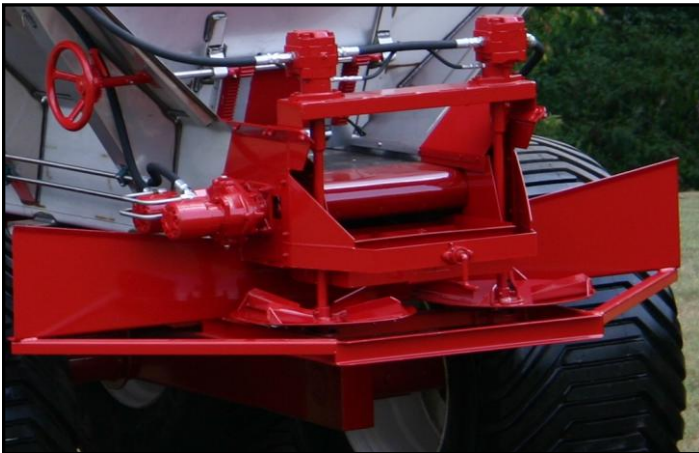

Tandem Axle Walking Beam Suspension:

850 / 50 – 30.5 Flotation Tires

20,000 # Hubs & Spindles

Chandler Equipment Co.

Gainesville, Georgia 30503 – 770-536-8891
Toll Free 1-800-243-3319, 770-535-1265 Fax

www.chandlerequipment.net