

CHANDLER MODEL 20 PTT - FT TANDEM AXLE PULL – TYPE FERTILIZER & LIME SPREADERS



(Shown in Mild Steel – 45 Degree Slope Sides)

- Overall Length 217” (18’)
- Overall Hopper Width 96” (8’)
- Overall Height 92” (7’ 8”)

- 245 Cu. Ft. Capacity (struck level)
(8 Tons based on 65 # Per Cu. Ft. Material)
- 10,000# Torsion Axles
- 16.5L x 16.1 Tires (standard)
- Available in Mild Steel,
409 Stainless & 304 Stainless Steel
Hopper Construction

Options:

- 52 Degree Slope Sides
(recommended for high rate lime applications)
- 19L x 16.1 Tires
- Narrow Track Option (30” Rows)
- Bolt On Frame
- Inverted “V”
- Bar Type Chain (recommended for lime application ONLY)
- Roll Tarp Assembly – available with 304 stainless or aluminum end caps
- Pintle Ring Hitch
- Constant Velocity PTO Shaft
- Variable Rate Control Systems Raven Industries
(when utilizing self – contained or plug to tractor hydraulic drive)

RAVEN

PLATINUM
PARTNER



(Shown with 304 Stainless Hopper 52 Degree Slope Sides)

Chandler Equipment Co.

Gainesville, Georgia 30503

Toll Free 1-800-243-3319

www.chandlerequipment.net

“Spreader Specifications”

(specifications shown are with 45 degree slope sides, standard axles & 16.5L x 16.1Tires)

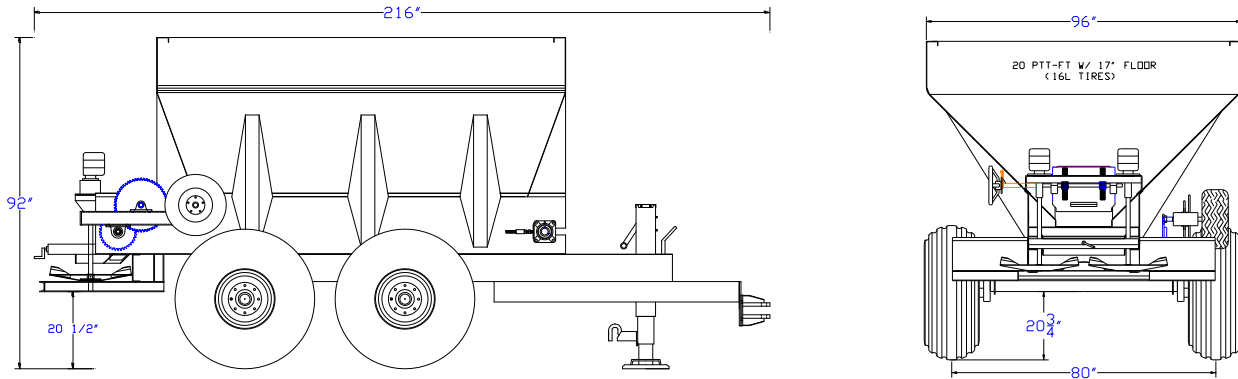

Frame & Suspension:

Axes: Tandem 10,000 # torsion axle, with 8 bolt hubs and spindles

Frame: Heavy Duty 7" Channel, with heavy duty adjustable clevis type hitch and 12,000 # jack

Conveyor Specifications:

Conveyor Type: 1" x 1" Heavy Duty type 304 stainless steel 16" – wide (Standard – see options listed on next page)

Conveyor Drive: Conveyor is press wheel driven with a 20.5 – 8 x 10 Tire.

Spinner Specifications:

Spinner Design: Twin “Dished Type” spinners, 24” diameter with 6 blades per spinner, specially designed for extremely accurate broadcasting of materials.

Material Divider:

Material divider is specially designed and adjustable for proper placement of material onto spinners for maximum accuracy in spread patterns. Material divider and adjustment screw are both manufactured from 304 Stainless Steel.

Metering Gate:

Rack and Pinion metering gate has quick adjust hand wheel and gate lock system for easy adjustment. The gate, gate slides, shaft and hanger brackets are manufactured from 304 stainless steel.

“Spinner Assembly”



Hydraulic Spinners
(Optional)



540 – RPM PTO Drive Spinners
(Standard)

“Conveyor Drive Assembly”



Hydraulic Drive Assembly
(Optional)



Press Wheel Drive Assembly
with Cylinder Engagement

Spinner Options:

- Hydraulic Drive Spinners (requires a minimum 16 GPM from Tractor Hydraulic System)
- 1000 – RPM PTO (in lieu of 540 – RPM)
- Stainless Steel Spinners and Blades
- Heat Treat Blades
- Stainless Steel Spinner Assembly: Spinners, Blades, Shafts, Hubs and Spread Shield

Conveyor Options:

- Steel Cleated Press Wheel
- Stainless Steel Roller Chain
- Hydraulic Drive – Plug to Tractor (requires control system)
- Self – Contained Hydraulic System (connects by PTO to Tractor)
- Optional Chain Widths: 20” & 24” Stainless Steel Mesh Type

Chandler Equipment Co.

Gainesville, Georgia 30503

Toll Free 1-800-243-3319

www.chandlerequipment.net