

CHANDLER TRUCK MOUNTED LITTER AND SHAVING SPREADERS



Lengths from
10' – 26'
(Options and
Specifications
listed inside
pages)

(Shown with optional hydraulic gate & dual tandem motor drive)

PTO Mechanical
Drive
or
Hydraulic Drive

Available with
control, guidance and
variable rate systems
from
Raven Industries



Leading the industry for over 45 years as the # 1
manufacturer of Poultry Litter Spreaders

Chandler Equipment Co.

Gainesville, Georgia 30503
Toll Free 1-800-243-3319

www.chandlerequipment.net

“Spreader Specifications”

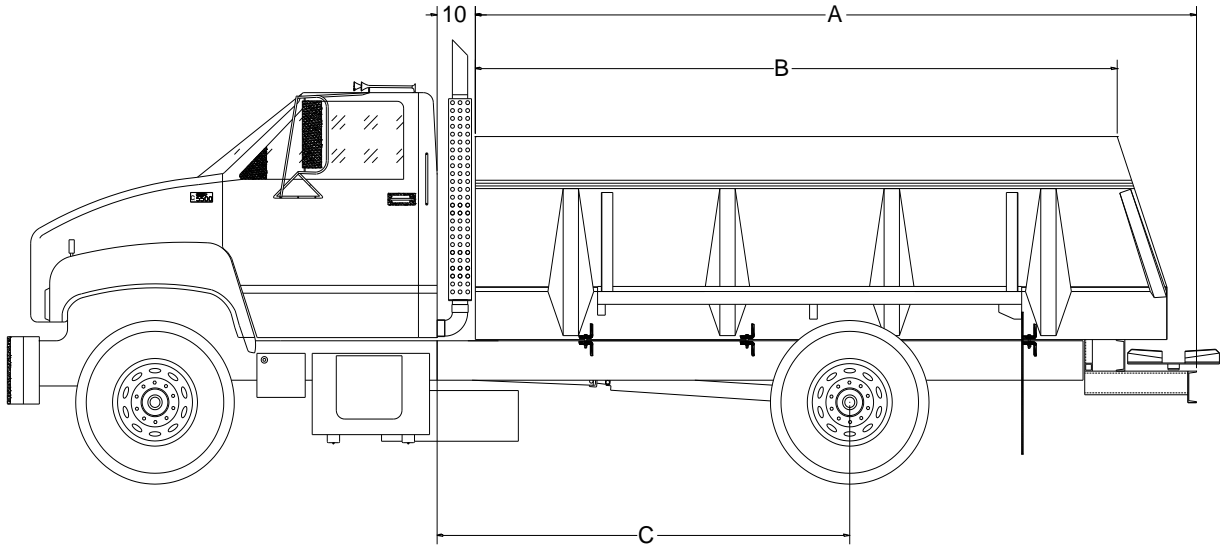
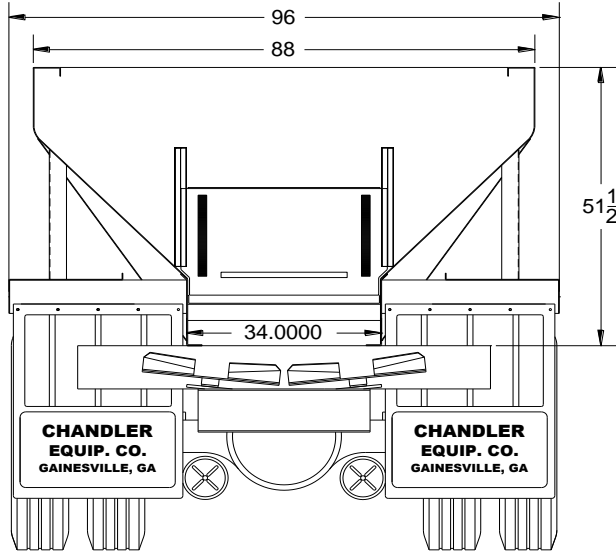

A. Overall Length: 12' 14' 16' 18' 20' 22' 24' 26'
 168" 192" 216" 240" 264" 288" 312" 336"
 (Overall length shown is with 24" spinners)

B. Hopper Length: 144" 168" 192" 216" 240" 264" 288" 312"

C. Cab to Center of Axle 84" 108" 120" 138" 148" 168" 180" 208"

Hopper Capacity: (cubic feet struck level)

	<u>12'</u>	<u>14'</u>	<u>16'</u>	<u>18'</u>	<u>20'</u>	<u>22'</u>	<u>24'</u>	<u>26'</u>
45 Degree Slope Sides:	236	275	315	355	394	433	473	512
52 Degree Slope Sides:	213	250	285	320	356	392	427	463

Standard Features

- Hopper Construction: Rails & Floor - 3/16" Plate Sides & Ends - 10 Ga. Mild Steel
- Power Source: Truck PTO with 50:1 worm gear drive with 2" cross shaft (standard)
- Conveyor: 34" wide bar type pintle chain with 3/8" thick bars on 11" centers
- Spinners: Twin 24" disc, 1/4" thick plate with four 9" blades on each (optional 30" spinners on hydraulic units)
- Lengths from: 10' to 26' available

Optional Features

Hopper Construction:

- 304 Stainless Steel Hopper
- 304 Stainless Steel Frame Rails & Floor
- 40" Wide Floor (shaving only except when using triple row chain option)
- UHMW Floor Liner
- Inverted "V" (for lime applications - hold weight off conveyor chain)
- Extra Heavy Duty Hopper
- 1/4" Rails and Floor
- 7 Ga. Sides and Ends
- Bolt – On Spinner Assembly
- Extension Brackets and Boards
- 52 Degree Slope Sides
- Floater Construction (designed to fit a floater type chassis)

Mechanical Drive (PTO)

- 2 –Speed Gear Case on Conveyor or Spinners (standard speed or shift to 1/3 of standard)
- Over-running coupler on spinners (allows spinner to free-wheel)

Hydraulic Options:

- Hydraulic System with Tandem Pump (with Electric Switch on Conveyor)
- Tandem Motor Gear Case on Conveyor
- Dual Tandem Motor Gear Cases on Conveyor
- Heavy Duty Spinner Motors
- Hydraulic Gate

Spinner Options:

- 30" Spinners with 4 - 11", 1/4" Thick Blades (hydraulic model ONLY)
- Heat Treated Spinner blades

Chain Options:

- Heavy Duty Chain – D667xc with 1/2" thick bars
- Triple Row Chain
- Close Spacing on Bars (4 1/2" or 2 1/4")

Tarp Options:

- Manual Roll Tarp
- Electric Roll Tarp

“Largest Choice of options of any litter spreader on the market”

CHANDLER TRUCK MOUNTED LITTER AND SHAVING SPREADERS



- Adjustable Flow Divider (for even spread patterns)
- Optional: 30" Spinners with 4 – blades each and accurate Spread Patterns out to 50' (depending on material)

- Optional: Floater Construction (Available in widths from 102" – 120" and lengths from 14'- 24')
- Optional: Dual Tandem Motor Gear Case



Chandler Equipment Co.

Gainesville, Georgia 30503

Toll Free 1-800-243-3319

www.chandlerequipment.net